

FEIDER

MACHINES



ELECTRIC LOG SAW

FSBE400

USER GUIDE

CAUTION: Read this manual before using this machine!

CONTENTS

1. SAFETY INSTRUCTIONS.....	3
2. DESCRIPTION.....	8
3. ASSEMBLY.....	8
4. OPERATION.....	17
5. MAINTENANCE AND STORAGE.....	19
6. DISPOSAL.....	22
7. DECLARATION OF CONFORMITY.....	22
8. WARRANTY.....	23
9. PRODUCT FAILURE.....	24
10. WARRANTY EXCLUSIONS.....	25

1. SAFETY INSTRUCTIONS

- **UNDERSTAND YOUR CUTTER**



Read and understand the owner's manual and labels affixed to the cutter. Learn its application and limitations as well as the specific potential hazards peculiar to it.

- **DRUGS, ALCOHOL AND MEDICATION**

Do not operate the cutter while under the influence of drugs, alcohol, or any medication that could affect your ability to use it properly.

- **AVOID DANGEROUS CONDITIONS**



Keep your work area clean and well lighted. Cluttered areas invites injuries.

Do not use the cutter in wet or damp areas or expose it to rain.

Do not use it in areas where fumes from paint, solvents or flammable liquids pose a potential hazard.

- **INSPECT YOUR CUTTER**



Check your cutter before turning it on. Keep guards in place and in working order. Form a habit of checking to see that keys and adjusting wrenches are removed from tool area before turning it on. Replace damaged, missing or failed parts before using it.

- **DRESS PROPERLY**



Do not wear loose clothing, gloves, neckties or jewelry (rings, wrist watches). They can be caught in moving parts.

Protective electrically non conductive gloves and non-skid footwear are recommended when working. Wear protective hair covering to contain long hair, preventing it from get caught in machinery.

- **PROTECT YOUR EYES AND FACE**



Any cutter may throw foreign objects into the eyes. This can cause permanent eye damage.

Always wear safety goggles. Everyday eyeglasses have only impact resistant lenses.

They are not safety glasses.

- **EXTENSION CORDS**

Improper use of extension cords may cause inefficient operation of the cutter which can result in overheating. Be sure the section of extension cord is enough to allow sufficient current flow to the Motor.

Avoid use of free and inadequately insulated connections. Connections must be made with protected material suitable for outdoor use.

- **AVOID ELECTRICAL SHOCK**

Check that the electric circuit is adequately protected and that it corresponds with the power, voltage and frequency of the motor. Check that there is a ground connection, and a regulation differential switch upstream.

Ground the cutter. Prevent body contact with grounded surfaces: pipes, radiators, ranges, and

refrigerator enclosures.

Never open the push button box on the motor. Should this be necessary, contact a qualified electrician.

Make sure your fingers do not touch the plug's metal prongs when plugging or unplugging the log saw.

A device for automatic disconnection of the power supply must to be installed by the user in the line powering the machine to protect people against electrical shock due to indirect contact in the machine.

- **KEEP VISITORS AND CHILDREN AWAY**



The cutter must be always operated by one person only. Other people should keep a safe distance from the work area, especially when the log saw is under operations. Never use another people to help you with freeing jammed log.

- **DON'T FORCE TOOL**

It will do a better and safer job at its design rate. Don't use the cutter for a purpose for which it was not intended.

- **DON'T OVERREACH**

Floor must not be slippery.

Keep proper footing and balance at all times.

Never stand on cutter. Serious injury could occur if the cutter is tipped or the blade or other moving parts are unintentionally contacted. Do not store anything above or near the log saw where anyone might stand on the tool to reach them.

- **AVOID INJURY FROM UNEXPECTED ACCIDENT**

Do not attempt to load the log on until the log pusher has stopped.

Keep hands out of the way of all moving parts.

- **PROTECT YOUR HANDS**



Keep you hands away from blade and cracks which open in the log; They may close suddenly and crush or amputate your hands.

Do not remove jammed logs with you hands.

- **NEVER LEAVE CUTTER RUNNING UNATTENDED**

Don't leave tool until it has come to a complete stop.

- **DISCONNECT POWER**



Unplug when not in use, before making adjustments, changing parts, cleaning, or working

on the log saw; Consult technical manual before servicing.

- **MAINTAIN YOUR CUTTER WITH CARE**

Keep the log saw clean for best and safest performance.

- **MAKE THE WORKSHOP CHILDPROOF**

Lock the shop. Disconnect master switches. Store the log saw away from children and others not qualified to use it.

- **A WARNING REGARDING RESIDUAL RISK**

The following risks are inherent to the use of these machines:

- Injuries caused by touching the rotating parts
- Injuries caused by disruption of the cutting blade

These risks are most evident:

- Within the range of operation
- Within the range of the rotating machine parts

In spite of the application of the relevant safety regulations and the implementation of safety devices, certain residual risks cannot be avoided. These are:

- Impairment of hearing.
- Risk of accidents caused by the uncovered parts of the rotating cutting blade.
- Risk of injury when changing the blade.
- Risk of squeezing fingers when opening the guards.

A. Braking should be verified every before use, running the machine, switch off then check the stopping time.

B. Only sawblades made in conformity to EN 847-1: 2013 shall be used on the machine;

C. The machine during indoor use shall be connected to an external chip and dust extraction system;

D. A Residual Current Device (RCD) should be used

● **SETTING AND MAINTENANCE REQUIRE**

A. The machine should be checked whether inner and outer blade cover, left and right side table moving cover, inner and outer flange of blade and blade are proper before operation.

B. Pushing the moving worktable forward and check whether left and right table moving cover and inner and outer blade touch each other so as to avoid unnecessary damage, while the log saw is working after turning-on the power.

C. Please turn off the power supply after using, cleaning the machine, save at dry airiness place.



Remove plug from mains before maintenance or if cord is damaged.



WARNING! Electricity - Risk of electric shock.



Warning symbol



Use a protection for face

● **SAFE WORKING PRACTICE**

It is essential all operators are:

A. Adequately trained in the use, adjustment and operation of the machine;

B. Instructed in factors that influence exposure to noise e.g.:

- i) Sawblade designed to reduce the emitted noise;
- ii) Sawblade and machine maintenance.

C. Informed of factors that influence exposure to dust e.g.:

- i) Type of material being machined;
- ii) Importance of local extraction (capture at source);
- iii) Proper adjustment of hoods/baffles/chutes;
- iv) Where provided, dust extraction equipment to be switched on before commencing machining.

It is important that:

D. During operation the machine is standing on level, horizontal ground and that the floor area around the machine is level, well maintained and free from loose material e.g. chips and off-cuts;

- E. Adequate general or localized lighting is provided;
 - F. Stock and finished workpieces are located close to the operators normal working position.
- It is essential for the operator to:**
- G. Use a push block or push stick to avoid working with the hands close to the sawblade when using a dual purpose circular sawing machine for firewood/circular saw bench in the saw bench mode;
 - H. Wear suitable personal protective equipment when necessary; this could include;
 - i) Hearing protection to reduce the risk of induced hearing loss;
 - ii) Respiratory protection to reduce the risk of inhalation of harmful dust;
 - iii) Gloves for handling sawblades (sawblades should be carried in a holder wherever practicable);
 - I. Refrain from cross cutting logs on a machine in the saw bench mode;
 - J. Stop the machine running whilst unattended;
 - K. Report faults in the machine, including guards or sawblades, as soon as they are discovered;
 - L. Adopt safe procedures for cleaning, maintenance and remove chips and dust regularly to avoid the risk of fire;
 - M. Follow manufacturers instruction for use, adjustment and repair of sawblades;
 - N. Select the correct riving knife, depending on the sawblade thickness, when using a dual purpose circular sawing machine for firewood/circular sawbench in the saw bench mode;
 - O. Observe the maximum speed marked on the sawblades;
 - P. Use correctly sharpened sawblades;
 - Q. Ensure that any spacers and spindle rings used are suitable for the purpose as stated by the manufacturer;
 - R. Refrain from removing any off-cut or other part of the workpiece from the cutting area whilst the machine is running except by using a push stick;
 - S. Ensure that guards and other safety devices necessary machine operation are in position, in good working order and properly maintained.
 - T. The installation and major repair work shall be carried out only by specifically trained personnel.

APPLICATION CONDITIONS

This machine is designed for hard/soft log cutting, not designed for commercial use, any other use is prohibited! Machine operating under ambient temperatures between +5°C and 40°C and for installation at altitudes no more than 1000m above M.S.L. The surrounding humidity should be less than 50% at 40°C. It can be stored or transported under ambient temperatures between -25°C and 55°C. Do not use the tool in a location where the risk of fire may be high.

In case of accident or breakdown, stop immediately the tool and do not use it. Check the tool. If repair is needed, bring the tool to an after sale service.

FREEING A JAMMED LOG

- Release both controls.
- After the log pusher moves back and completely stops at its starting position, insert a wedge wood under the jammed log.
- Start the log splitter to push the wedge wood to go completely under the jammed one.
- Repeat above procedure with sharper slope wedge woods until the log is completely freed

SPECIFICATIONS

Model Number	FSBE400
Motor	230V~ 50Hz, S6 40%, 2200W, IP54
No load speed	2800/min

Cutter Capacity	Ø30-Ø135mm
Saw blade	Ø405mm×Ø30mm×3.2mm×32T
Weight	32 kg
IP Number	IP54

ELECTRICAL REQUIREMENTS

With 230 Volt~50Hz motor, the log saw should be connected to standard 230V±10%/50Hz.

Connect the 230VAC motor using a power cable in a minimum section of 1.5mm²(cable specs 3×1.5).Power feeding is performed via a control switch electrically connected between a power source(plug) and the drive motor.

Sound power level L_{WA}=104 dB (measured value)

Sound pressure level L_{pa} = 92 dB

Associated uncertainty K=2 dB

Measurement made in accordance with EN ISO3746: 2010

The figures quoted are emission levels and are not necessarily safe working levels. Whilst there is a correlation between the emission and exposure levels, this cannot be used reliably to determine whether or not further precautions are required. Factors that influence the actual level of the workforce include the characteristics of the work room, the other sources of noise etc.i.e. the number of machines and other adjacent processes. Also the permissible exposure level can vary from country to country. This information, however, will enable the user of the machine to make a better evaluation of the hazard and risk.

WIRING DIAGRAM

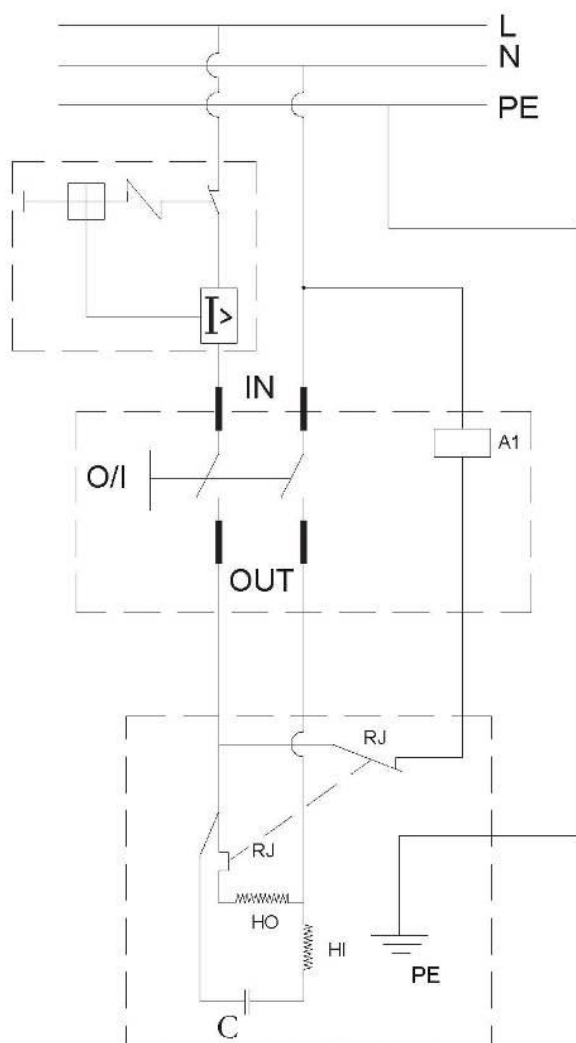

2. DESCRIPTION

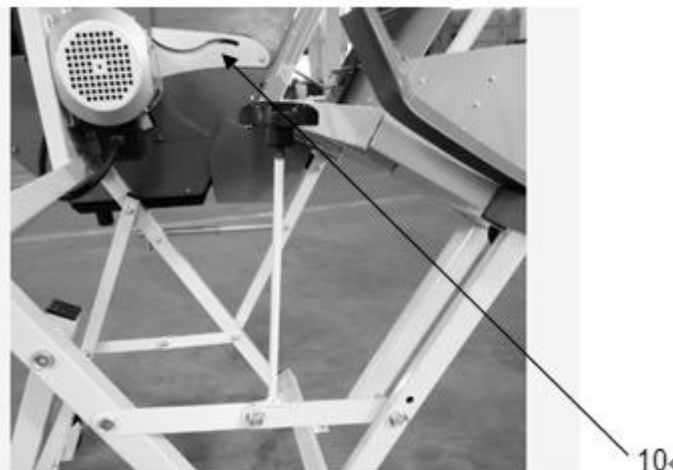
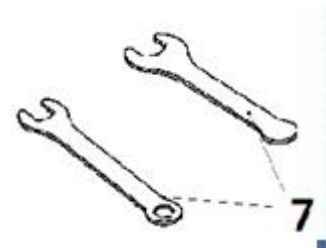
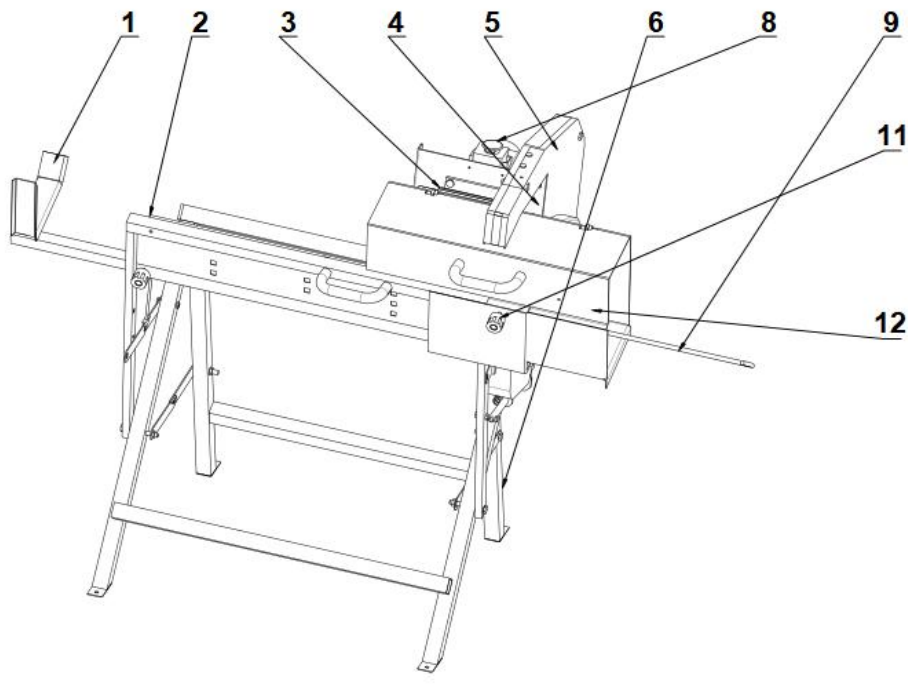

- | | |
|--------------------------|--------------------|
| 1. Sliding support | 7. Spanner (2X1) |
| 2. working table | 8. On/Off switch |
| 3. Motor | 9. extended holder |
| 4. Saw blade inner guard | 10. Guide plate |
| 5. Saw blade outer guard | 11. locking knob |
| 6. Support leg | 12. Table cover |

3. ASSEMBLY

1. Unpacking

 **Danger! Hazard generated by missing parts!**

To prevent accidental starting that could cause possible serious personal injury, assemble all parts to your machine before connecting it to power supply. This machine should never be connected to power supply when you are assembling parts, making adjustments, installing.

Carefully remove all parts from the carton and place the machine on a level work surface. Separate









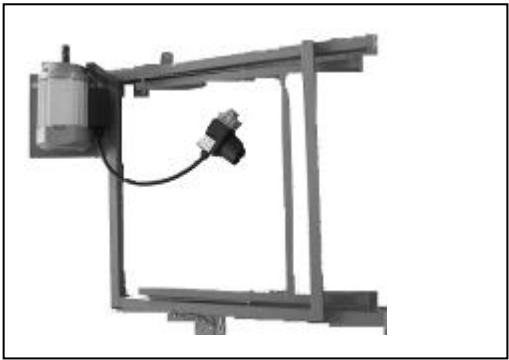

and check against the list of loose parts.

If any parts are missing, do not operate this machine until the missing parts are replaced. Failure to do so could result in serious personal injury.

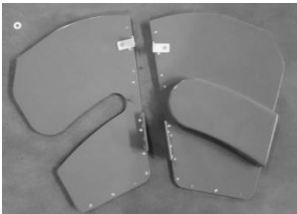
Do not discard the packing materials until you have carefully inspected the machine, identified all parts, and satisfactorily operated this machine.

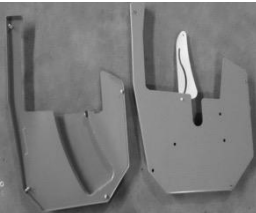
NOTE: If any parts are damaged or missing, do not attempt to plug in the power cord and turn the switch on until the damaged or missing parts are obtained and are installed correctly.

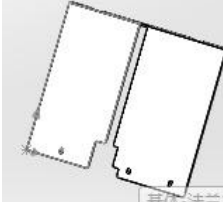
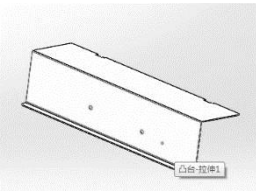
2. Loose parts list

		
<p>A. Supporting leg (B) with motor 1pc</p>	<p>B. Supporting leg (A) with working table 1pc</p>	
 <p>C. Sliding support 1pc</p>	 <p>D. Inner flange 1pc</p>	 <p>E. Outer flange 1pc</p>
 <p>F. Saw blade guard 1pc</p>	 <p>G. Saw blade 1pc</p>	 <p>H. Saw blade inner guard 1pc</p>  <p>I. Parts plastic bag for fasten parts.</p>
 <p>J. extended holder 1pc</p>	 <p>K. Table cover plate</p>	 <p>L. Table cover</p>  <p>M, Parts plastic bag for handles and locking knob ,fasten parts.</p>

I. Parts plastic bag for spanners contains: 2 pcs of spanners for changing saw blade

II. Parts plastic bag for screws, bolts, nuts, washers and etc. contains:

No.	Description	Specifications	Q'ty	No.	Description	Specifications	Q'ty				
1. Procedure 1				2. Procedure 2							
1	Screw	M4X55	4	1	Screw	M6X25	2				
2	Bolt	M8X60	2	2	Nut	M6	1				
3	Flat washer	Ø8	4	3	Locking nut	M6	2				
4	Locking nut	M8	2	4	Washer	Ø6	2				
5	Washer	Ø4	4	5	Screw	M5X8	4				
3. Procedure 3				4. Procedure 4							
1	Coach Bolt	M8X15	2	1	Coach bolt	M6X50	4				
2	Screw	M8X15	1	2	Locking nut	M6	4				
3	Bolt	M8X40	1	3	Washer	Ø6	4				
4	Cross groove screw	M6x15	3	4	cross groove head screw	M6X8	2				
5	Washer	Ø6	3								
6	Flat washer	Ø8	4								
7	Locking nut	M8	4								
8	Locking nut	M6	3								
9	Semicircle head inner-hex screws	M6x12	4								
10	Screw	M5x15	1								
11	Nut	M6	1								
12	Washer	Ø5	1								
13	Locking nut	M5	1								
14	Screw	M5X12	2								
15	Washer	Ø5	2								
16	Spring washer	Ø5	2								
5. Procedure 5											
1	Locking knob		1								
2	Locking knob		1								

Remark: All the fasten parts and spare parts are listed in the table will be used for assembly as the following detail **“Machine installation”** procedures.

3. Mains connection



Danger! High voltage!

Operate the machine only on a power source matching the following requirements (see also “Technical specifications”):

- Outlets with neutral wire, being properly installed, earthed and tested.
- Mains voltage and frequency must conform with the date stated on the machine’s nameplate.
- Fuse protection by a residual current device (RCD) of 30 mA fault current sensitivity.

System impedance Z_{max} . at the interconnection point (house service connection) 0.35 Ohm maximum.

NOTE: Check with your local Electricity Board or electrician if in doubt whether your house service connection meets these requirements.

Position power supply cable so it does not interfere with the work and is not damaged.
Protect power supply cable from heat, aggressive liquids and sharp edges.
Use only rubber-jacked cable of sufficient lead cross section as extension cable.
Do not pull on power supply cable to unplug.

4. Machine installation

Warning: to avoid machine overturning or falling during the assembly/disassembly process, please follow carefully below steps for machine assembly and reverse steps for machine disassembly.

- Align the two holes on the supporting leg (A) into the two holes on the supporting leg (B), and use 2 bolts (M8X40), 2 washers (Ø8) and 2 locking nut (M8) to fasten these two legs together, and leave the supporting leg to lie on the ground.

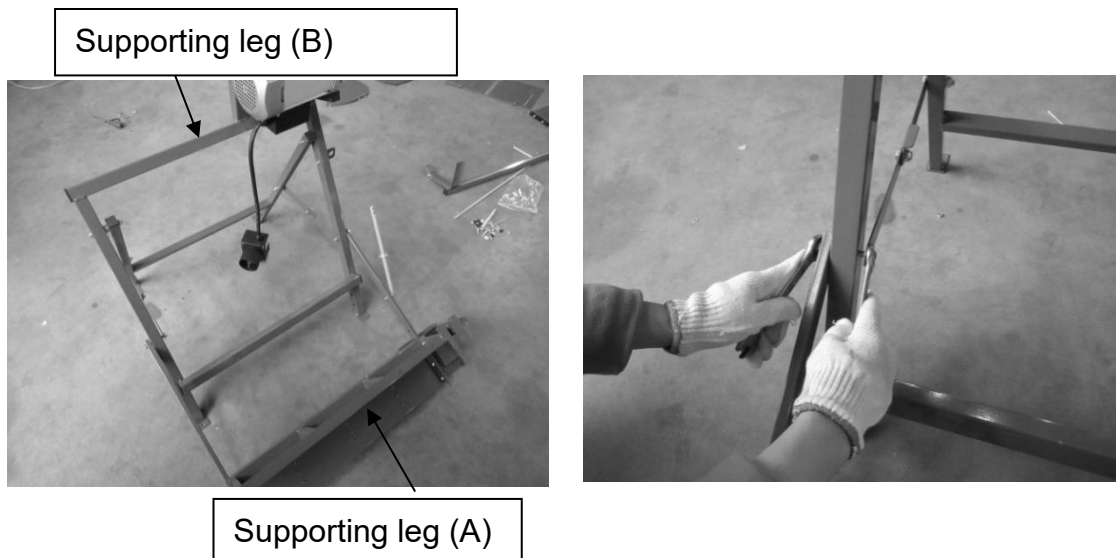

- Assemble the limited rod, use M8X25 bolt and M8nut to fix, pls note that not tighten so that the rod can move.



- Assemble the saw blade outer guard on the supporting leg (B) and guard support, with cross countersunk bolt (M6x15), bolt (M8x40), bolt (M8X15), locking nut(M6),locking nut(M8).

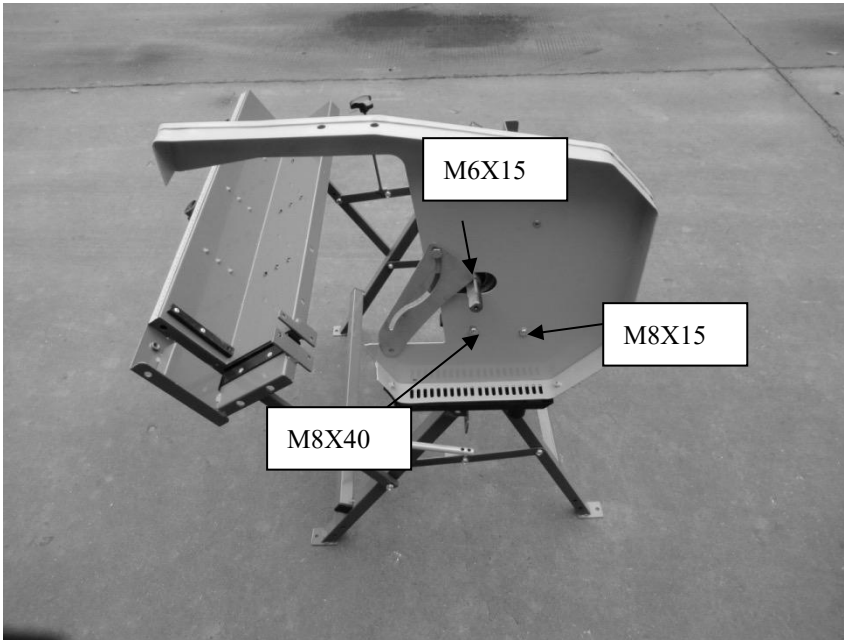

- Assemble inside of saw blade inner guard and connect it to the worktable, and mount the movable baffle.

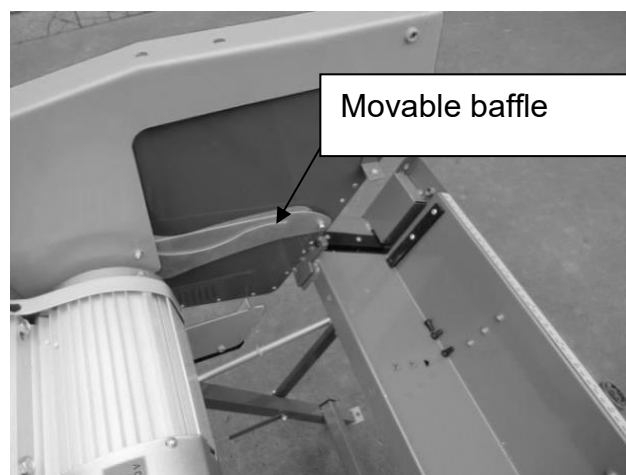

- Assemble the Lower cover, use screw M6X12 to connect the lower cover to worktable, and use screw M6X25 to fix.

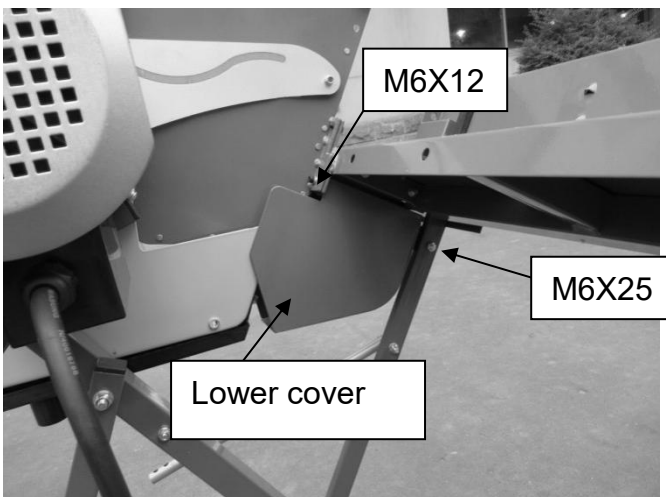

- Put the inner flange, blade, outer flange and M20 nut on the motor shaft. Hold outer flange with spanner and fasten the nut by spanner.



- Assemble the outside of sawblade inner guard, connect it to the worktable with 2 screws(M6x12),then use screws(M5x6) to connect the the outside and inside of inner sawblade guard.

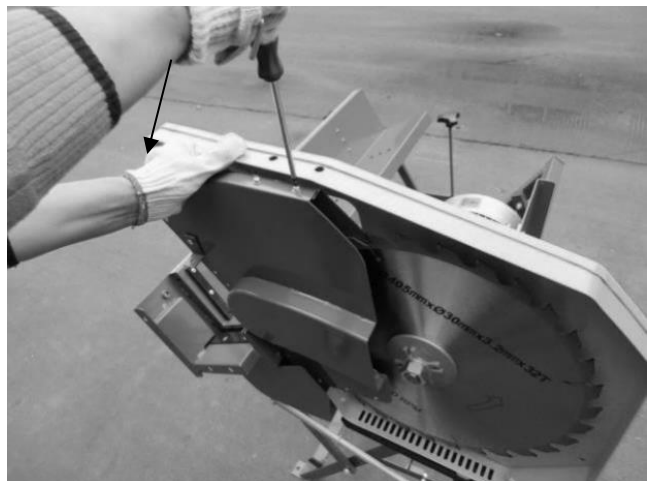

- Assemble the sawblade outer guard, pls remove the lower plastic cover of inner guard first, mount the outer guard and tighten the bols of outer guard,then mount the lower plastic cover.

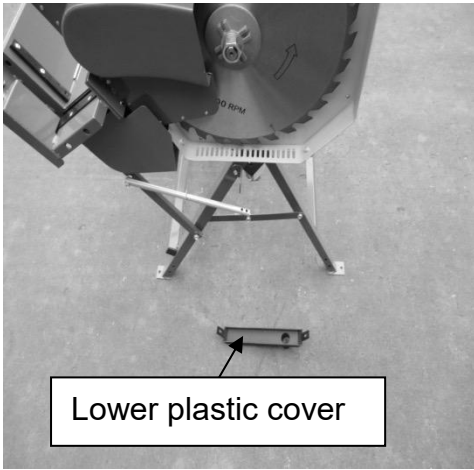

- Assemble the extension worktable, use 2 bolts (M8X12), 2 washers (Ø8) and 2 locking nuts (M8) to connect the extension worktable to worktable.



- Assemble the table cover plate, use 3 bolts(M8X15), 3 locking nuts (M8) to connect the table cover plate to worktable, then use 2 bolts(M5X8) ,2 locking nuts (M5) to connect the table cover plate to sawblade inner guard.

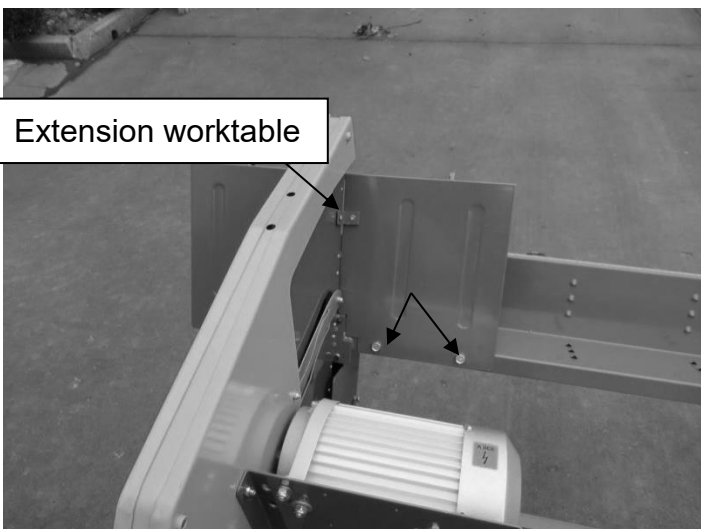

- Assemble the table cover.

- a. Assemble the handle



- b. Loosen 2 screws (M4X6) of the table cover, then connect it to the table cover plate and tighten 2 screws (M4X6)

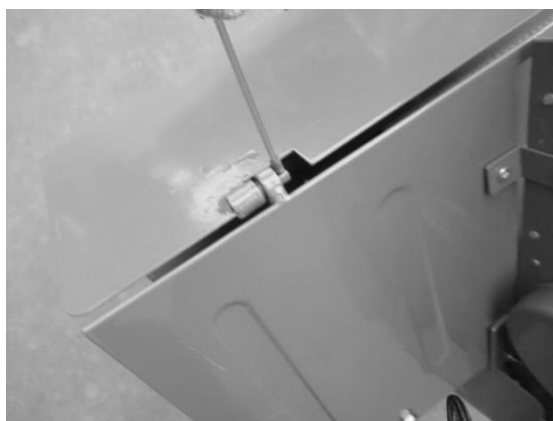

- Install the sliding support, extended holder, handle

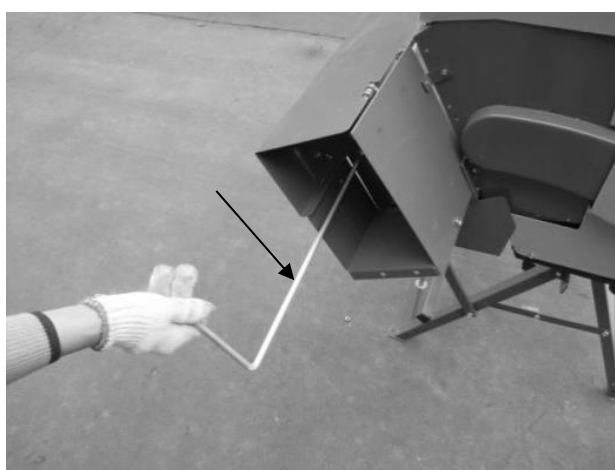

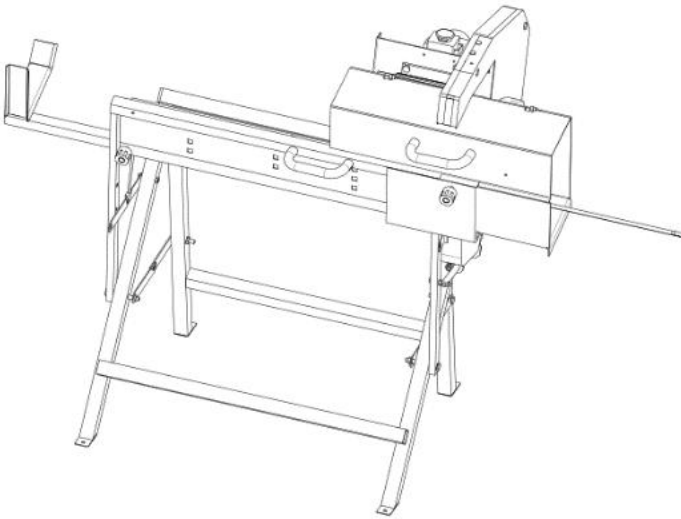

- Install 2 knobs (M8X20)

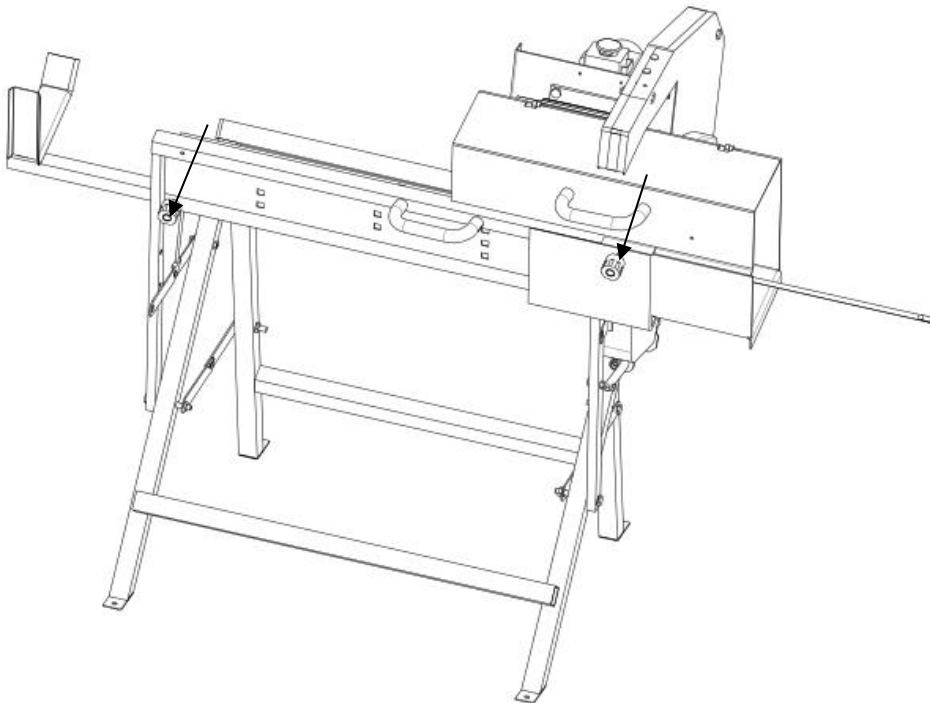

- Install spring guide tube, loosen bolt ,flat washer and locking nut on spring guide tube , put spring and washer onto spring guide tube, push the supporting leg (A) towards the blade, and insert spring guide tube into hole on supporting leg(B) and fasten it .



- Mount the switch back on the motor plate by 4 Bolts (M4X55).

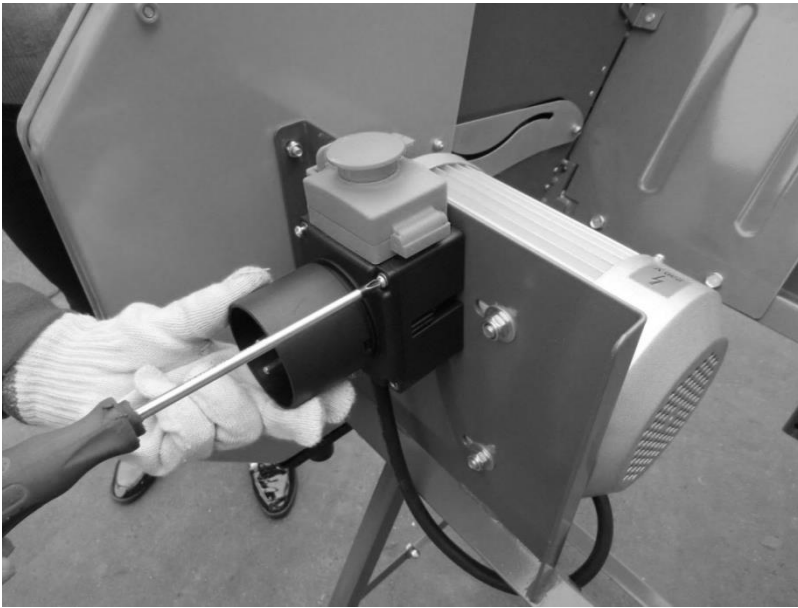

4. OPERATION

Please take note of the following safety information before operating the machine!
Also follow the safety instructions given at the beginning of this manual!

 **Hazard generated by machine defects!**

NOTE: Before Using the Machine, Please fix the 4 holes with Bolts (M8X20) at the Bottom of the Stand to avoid overturning or moving during the operation!

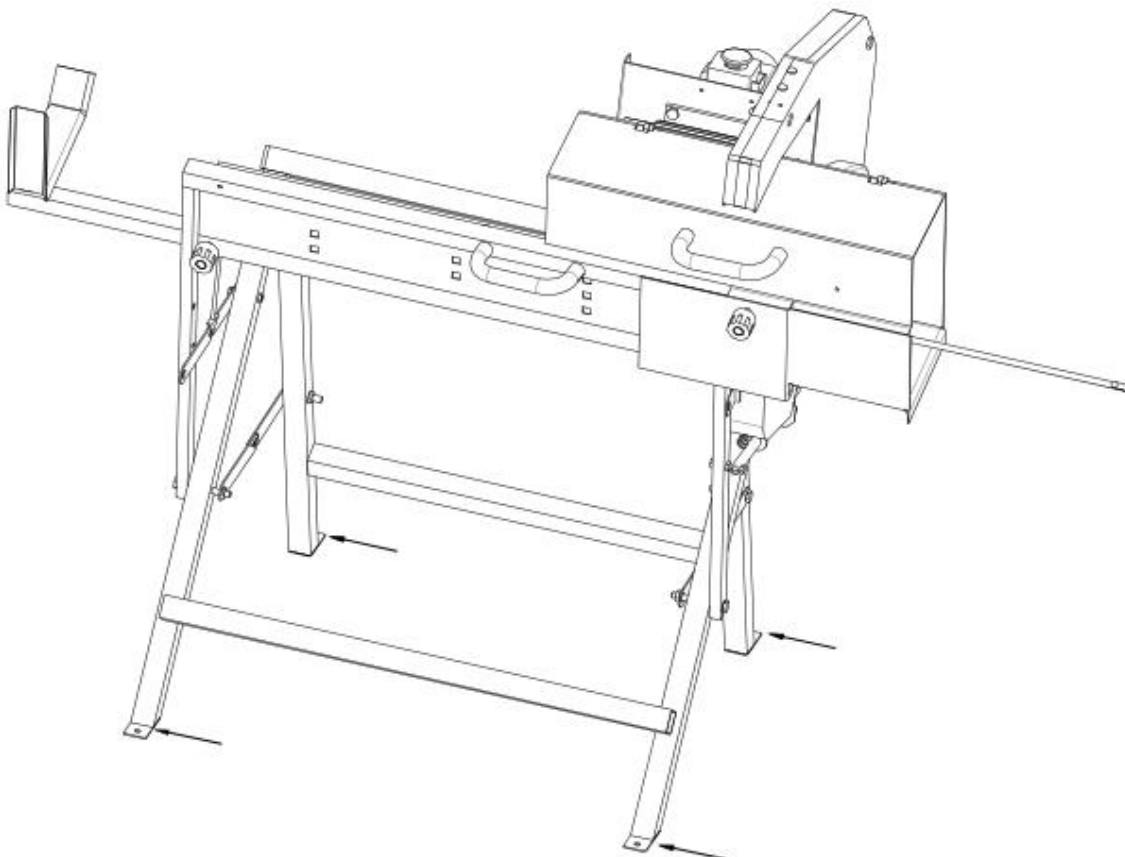

Before starting work, check to see that the following are in proper working order:

1. Saw blade (firmly mounted? Undamaged? Sharp? Sufficient distance to other parts?)
2. Blade guard (undamaged? Distance to saw blade sufficient?)
3. Working table (must automatically return to the starting position)
4. Power cable, power cable plug and switch (if damaged, have replaced to a qualified electrician)
5. Motor brake (after switching OFF maximum 10 seconds post-running of saw blade)

 **Risk of injury by inhaling wood dust!**

Dust of certain timber species (e.g. oak, beech, ash) can cause cancer when inhaled:

1. Work only out of doors.
2. When working, take care that as little wood dust as possible will get into the surroundings.
3. Remove wood dust depositions in the work area (do not blow away!).
4. Note: the design of this machine is based on a conveying velocity of extracted air in the duct of 20 ms^{-1} for dry chips and 28 ms^{-1} for wet chips (moisture content 18% or above).

 **Hazard generated by insufficient personal protection gear!**

1. Wear suitable work clothing, providing protection against falling logs.
2. Wear hair protection.
3. Wear safety glasses.
4. Wear dust mask
5. Wear non-slip safety shoes.
6. Take care that no parts of your body or clothing are caught by rotating components (do not wear ties or loose fitting garment; contain long hair with a hairnet).

 **Risk of personal injury and crushing by moving parts!**

1. Do not operate the machine without installed guards.
2. Keep sufficient distance to driven components when operating the electric tool.
3. Do not remove small cutoffs, splinters, etc. from near the rotating saw blade by hand.
4. Always use the feed rocker to feed the logs to be cut.
5. Always hold the feed rockers with both hands at its handle.
6. Assume proper operating position:
 - In the front of the saw;
 - Offset to the line of cut.
7. After each cut return the working table completely to its starting position.

 **Hazard generated by pieces of wood being hurled away!**

1. Always place curved logs on the working table with the curved side facing the saw blade.
2. Do not jam the log to be cut.
3. Do not attempt to stop the saw blade by pushing the workpiece against its side.
4. Always use sharp saw blades.
5. If in doubt, inspect the logs for foreign matter (e.g. nails or screws).
6. Never cut several logs at the same time. Risk of personal injury.

Cutting

1. Start machine and let the motor reach full speed.
2. Place a log on the working table
3. To make the cut, push the working table with both hands at the handle towards the saw blade:

- Exert only so much pressure that the motor speed does not fall off.
- Push feed working table until it hits the stop.

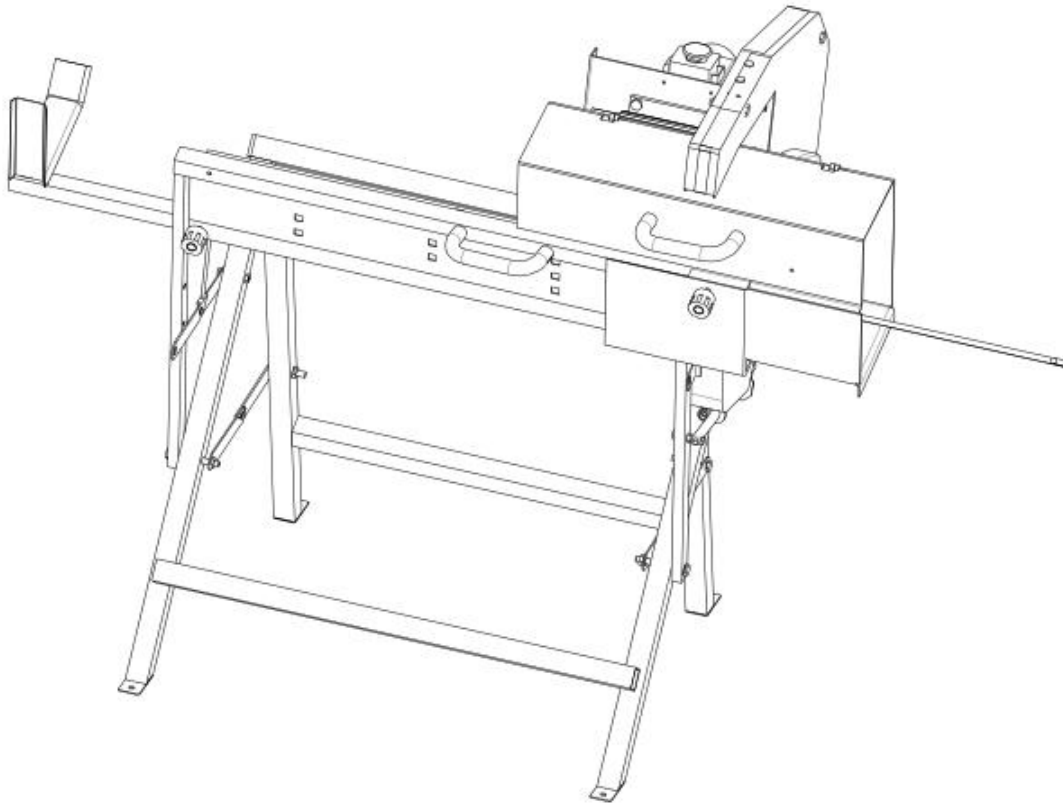

4. Return working table completely to the starting position.

NOTE: If the log was not completely separated, turn it over and repeat the cutting operation from the opposite side (reversing cut).

5. Remove the cut off piece then make next cut...
6. If no further cutting is to be done immediately afterwards, turn machine OFF.

5. MAINTENANCE AND STORAGE



Danger! Prior to all servicing:

- Switch machine OFF;
 - Wait for saw blade to complete stop;
 - Unplug power cable;
1. Check that all safety devices are operational again after each service.
 2. Replace damaged parts, especially safety devices, only with genuine replacement parts since parts not tested and approved by the equipment manufacturer can cause unforeseeable damage.
 3. Repair and maintenance work other than described in this section should only be carried out by qualified specialists.

Saw blade change



Danger! Directly after cutting the saw blade can be very hot – burning hazard! Let a hot saw blade cool down. Do not clean the saw blade with combustible liquids. Risk of injury, even with the blade at standstill. Wear gloves when changing blades. When assembling, observe the direction of rotation of saw blade!

1. Loosen all coach screws, washers, locking nuts on right blade outer guard. And remove the right outer blade guard.

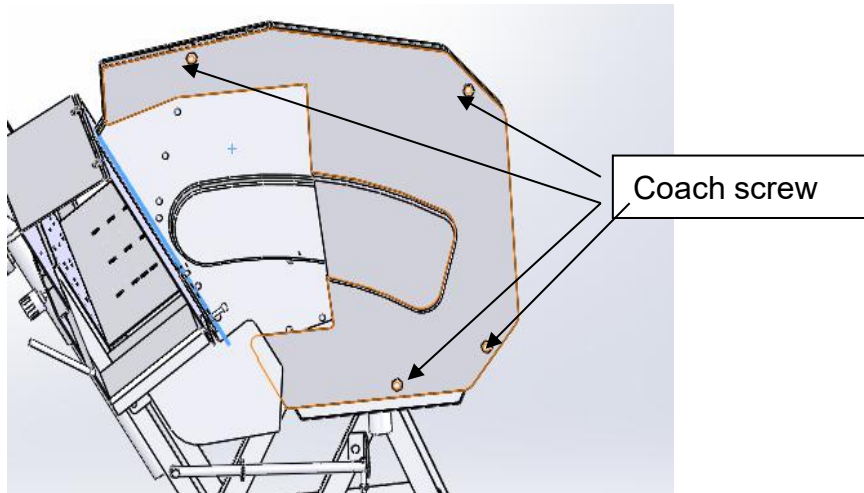

2. Loosen 2 semicircle groove head screw and 2 spring washer, 2 washer on the blade inner guard

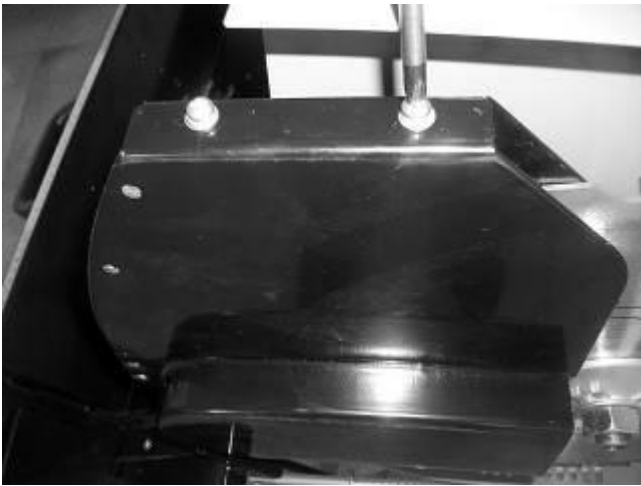

3. Loosen 2 semicircle head inner-hex screws on the right blade inner guard

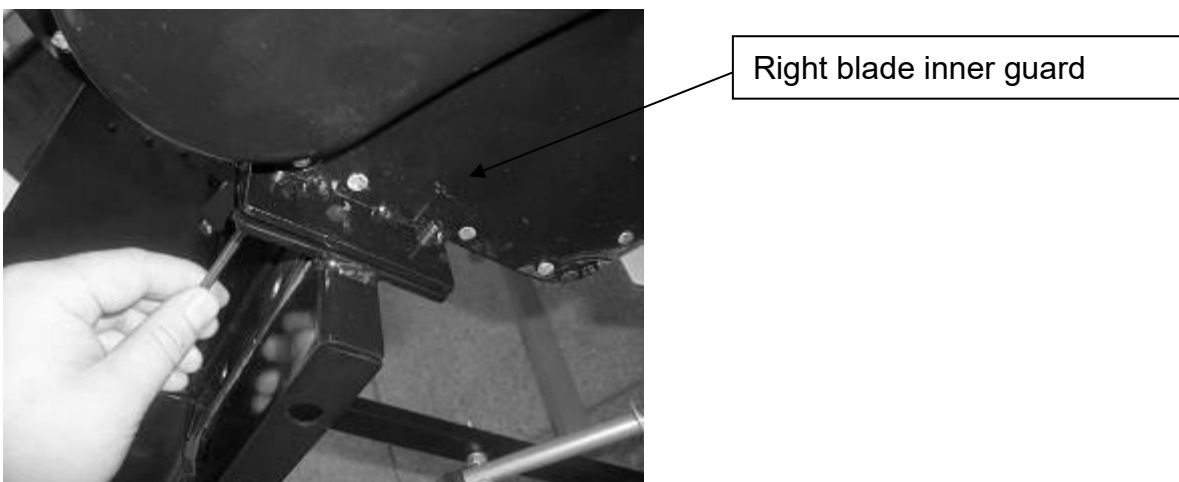

4. Hold outer flange (14) with spanner and loosen the nut (13) by spanner.

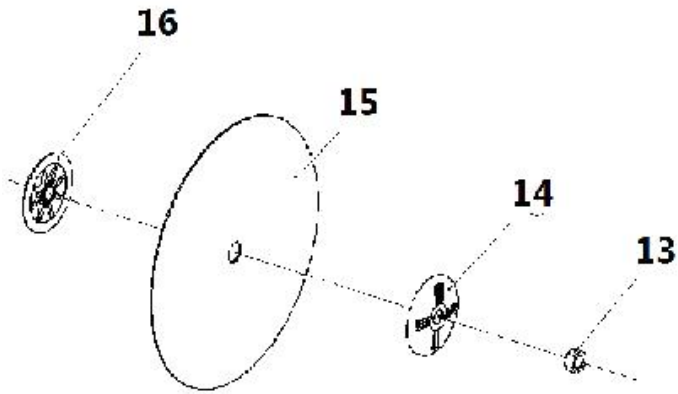

5. Remove the nut (13) and outer flange (14) from the saw spindle
6. Take the saw blade (15) off the saw spindle.
7. Clean clamping surfaces of :
 - saw spindle,
 - inner flange,
 - saw blade,
 - outer blade flange,
 - nut.



Danger! Do not use cleaning agents (e.g. to remove resin residue) which could corrode the light alloy components; this can have an adverse effect on the machine's stability. Do not clean the saw blade with combustible liquids.

8. Install new saw blade (15), observing the direction of rotation.



Danger! Use only saw blades conforming to the technical specifications and EN 847-1 – parts of unsuitable or damaged saw blades may be hurled away explosive-like.

Do not use:

- saw blades made of high speed steel (HS or HSS);
- saw blades with visible damage;
- cut-off wheel blades.

Saw storage



Danger! Store saw so that:

- it can not be started by unauthorized persons, and
- nobody can get injured.



Caution! Do not store saw unprotected outdoors or in damp environment.

NOTE: Always install the transport brace to avoid overturning or falling during the transporting process!

To keep the saw blade from rusting, spray with Cleaning and Maintenance Spray (optional accessory) before storing it for a longer time.

Every 50 hours of operation:

- Check all screwed connections, tighten if necessary (Rocker and rocker stop must remain movable).
- Check saw blade for firm seat, wear and sharpness.
- Remove any deposits that may have build up inside the saw blade cover.

6. DISPOSAL



Electrical products should not be discarded with household products. According to the European Directive 2012/19/EU on waste electrical and electronic equipment and its implementation into national law, electrical products used must be collected separately and disposed of at collection points provided for this purpose. Talk with your local authorities or dealer for advice on recycling

7. DECLARATION OF CONFORMITY



BUILDER SAS

ZI, 32 rue Aristide Bergès – 31270 Cugnaux - France
Tel: +33 (0)5.34.502.502 Fax: +33 (0)5.34.502.503

The undersigned, hereby certifies that the units described below
ELECTRIC LOG SAW
Model: FSBE400

S/N: 20230605545-20230605650

is in compliance with the provisions of the following European directives:

2014/30/EU " ElectroMagnetic Compatibility "

2006/42/EC "Machinery"

ROHS Directive 2011/65/EU and 2015/863/EU

And to the following standards:

EN 1870-6: 2017

EN 60204-1: 2018

EN55014-1: 2017/A11:2020

EN IEC55014-1: 2021

EN55014-2: 1997/A2:2008

EN IEC55014-2: 2021

EN61000-3-2: 2014

EN IEC61000-3-2: 2019/A1:2021

EN61000-3-11: 2000

EC-type certificate number: M6A 058058 0426 Rev. 01

Notified Body: No 0123

TÜV SÜD Product Service GmbH · Zertifizierstelle · Ridlerstraße 65 · 80339 München · Germany

Sound power level $L_{WA}=104$ dB K=2 dB

The people name holding the technical file: Mr. Olivier Patriarca
Cugnaux, 15/05/2023

Philippe MARIE / PDG

8. WARRANTY



WARRANTY

The manufacturer guarantees the product against defects in material and workmanship for a period of 2 years from the date of the original purchase. The warranty only applies if the product is for household use. The warranty does not cover breakdowns due to normal wear and tear.

The manufacturer agrees to replace parts identified as defective by the designated distributor. The manufacturer does not accept responsibility for the replacement of the machine, in whole or in part, and/or ensuing damage.

The warranty does not cover breakdowns due to:

- insufficient maintenance.
- abnormal assembly, adjustment or operations of the product.
- parts subject to normal wear and tear.

The warranty does not extend to:

- shipping and packaging costs.
- using the tool for a purpose other than that for which it was designed.
- the use and maintenance of the machine done in a manner not described in the user manual.

Due to our policy of continuous product improvement, we reserve the right to alter or change specifications without notice. Consequently, the product may be different from the information contained therein, but a modification will be undertaken without notice if it is recognized as an improvement of the preceding characteristic.

READ THE MANUAL CAREFULLY BEFORE USING THE MACHINE.

When ordering spare parts, please indicate the part number or code, you can find this in the spare parts list in this manual. Keep the purchase receipt; without it, the warranty is invalid. To help you with your product, we invite you to contact us by phone or via our website:

- **+33 (0)9.70.75.30.30**
- **<https://services.swap-europe.com/contact>**

You must create a "ticket" via the web platform.

- Register or create your account.
- Indicate the reference of the tool.
- Choose the subject of your request.
- Describe your problem.
- Attach these files: invoice or sales receipt, photo of the identification plate (serial number), photo of the part you need (for example: pins on the transformer plug which are broken).



9. PRODUCT FAILURE

WHAT TO DO IF MY MACHINE BREAKS DOWN?

If you bought your product in a store:

- a) Empty the fuel tank if your product has one.
- b) Make sure that your machine is complete with all accessories supplied, and clean! If this is not the case, the repairer will refuse the machine.

Go to the store with the complete machine and with the receipt or invoice.

If you bought your product on a website:

- a) Empty the fuel tank if your product has one.
- b) Make sure that your machine is complete with all accessories supplied, and clean! If this is not the case, the repairer will refuse the machine.
- c) Create a SWAP-Europe service ticket on the site: <https://services.swap-europe.com> When making the request on SWAP-Europe, you must attach the invoice and the photo of the nameplate (serial number).
- d) Contact the repair station to make sure it is available before dropping of the machine.

Go to the repair station with the complete machine packed, accompanied by the purchase invoice and the station support sheet downloadable after the service request is completed on the SWAP-Europe site

For machines with engine failure from manufacturers BRIGGS & STRATTON, HONDA and RATO, please refer to the following instructions.

Repairs will be done by approved engine manufacturers of these manufacturers, see their site:

- <http://www.briggsandstratton.com/eu/fr>
- <http://www.honda-engines-eu.com/fr/service-network-page;jsessionid=5EE8456CF39CD572AA2AEEDFD290CDAE>
- <https://www.rato-europe.com/it/service-network>

Please keep your original packaging to allow for after-sales service returns or pack your machine with a similar cardboard box of the same dimensions.

For any question concerning our after-sales service you can make a request on our website <https://services.swap-europe.com>

Our hotline remains available at +33 (9) 70 75 30 30.



10. WARRANTY EXCLUSIONS

THE WARRANTY DOES NOT COVER:

- Start-up and setting up of the product.
- Damage resulting from normal wear and tear of the product.
- Damage resulting from improper use of the product.
- Damage resulting from assembly or start-up not in accordance with the user manual.
- Breakdowns related to carburetion beyond 90 days and fouling of carburetors.
- Periodic and standard maintenance events.
- Actions of modification and dismantling that directly void the warranty.
- Products whose original authentication marking (brand, serial number) has been degraded, altered or withdrawn.
- Replacement of consumables.
- The use of non-original parts.
- Breakage of parts following impacts or projections.
- Accessories breakdowns.
- Defects and their consequences linked to any external cause.
- Loss of components and loss due to insufficient screwing.
- Cutting components and any damage related to the loosening of parts.
- Overload or overheating.
- Poor power supply quality: faulty voltage, voltage error, etc.
- Damages resulting from the deprivation of enjoyment of the product during the time necessary for repairs and more generally the costs related to the immobilization of the product.
- The costs of a second opinion established by a third party following an estimate by a SWAP-Europe repair station
- The use of a product which would show a defect or a breakage which was not the subject of an immediate report and/or repair with the services of SWAP-Europe.
- Deterioration linked to transport and storage*.
- Launchers beyond 90 days.
- Oil, petrol, grease.
- Damages related to the use of non-compliant fuels or lubricants.

* In accordance with transport legislation, damage related to transport must be declared to carriers within 48 hours maximum after observation by registered letter with acknowledgement of receipt.

This document is a supplement to your notice, a non-exhaustive list.

Attention: all orders must be checked in the presence of the delivery person. In case of refusal by the delivery person, it you must simply refuse the delivery and notify your refusal.

Reminder: the reserves do not exclude the notification by registered letter with acknowledgement within 72 hours.

Information:

Thermal devices must be wintered each season (service available on the SWAP-Europe site). Batteries must be charged before being stored.



BUILDER SAS

32 rue Aristide Bergès - Z.I. du Casque - 31270 Cugnaux - France

Made in PRC